

LEDGEAR® Specification

GENERAL GUIDELINES.....	1	Insulation between circuits.....	8
PARAMETERS.....	3	Release of the wiring.....	9
DRIVER PERFORMANCE CURVE.....	5	Looping Circuit diagram.....	9
DIMMING OPERATION.....	6	Wiring type and cross section.....	10
AM&PWM dimming technique.....	6	Wiring guidelines.....	10
PUSH Dimming.....	6	Miniature circuit breaker application.....	10
DALI 2 Dimming.....	7	Fixing conditions.....	11
DIAGRAM&INSTALLATION MANUAL.....	8	DIP Switch Table.....	11
Isolated circuit (Fly-back CV + DC-DC control).....	8	MECHANICAL.....	11
		PACKAGING.....	11

GENERAL GUIDELINES

LEDGEAR® C9, the most compact design DALI-2 looping LED driver in the world, which covering all the wattage within 15W(350mA) for indoor lighting, especially suitable for cut out hole no less than 66mm, and bigger but with small ceiling void.

The driver equipped with push-fit terminals, which enable through wiring of Primary, DALI and Push wires throughout the driver, and save lots of time and effort on a site's actual wiring work. The terminals allow quick cable connections without any tool, and also support a variety of wire gauge and cable thicknesses.

Assembled with 4xDIP switches, the driver allows output current selectable, or programmed any output current by DALI. Variable output voltage of 14-40V with constant current output. These wide operating windows and easy wiring for LED modules makes it super flexibility and warehouse inventory reduction.



LED Electronic Looping Control Gear

DALI-2, Push-Dim Constant Current Output

With 14-40VDC 120mA-350mA Adjustable Output Series

Product description

- Design DALI-2 & Push-DIM 2in1 dimming
- Min. cut-out hole diameter 66mm for recessed downlights
- Reliable, Class II, SELV according EN 61347
- ENEC, CE, CB approved by TUV SUD, SAA, Ctick qualified
- EcoDesign Directive (EU) 2019/2020 compliant
- Tool-less installation and with through wiring
- ENHANCED amplitude dimming technology
- $\pm 5\%$ output current accuracy (under maximum load)
- Protection for output open load, short circuits, over voltage and over temperature
- Built-in with permanent memory for DALI and Push-DIM, 100,000 times memory
- 80°C Maximum case operation temperature (tc-point ¹)
- Operating temperature ¹: -25°C ~ +55°C, the humidity: 20% ~ 85%
- Over 60,000 hrs nominal lifespan at tc=65°C
- Five-year factory guarantee and lifetime technical support ¹

¹ Detailed data please refer to the "PARAMETERS" table .

Features & Benefits

Flexibility & Optimized Inventory

- Both model covers wattages from 4.8W to 14W and differs in lifespan
- Wattage selectable by 3xDIP switches.
- Push-fit secondary terminals for LED module wires

Human Centric Design

- Easy & Quick connection with push-fit terminals and clip-on end cap for strain relief, super large wiring space
- Loop in & loop out function, max. 2.5mm² cross section L, L, N, N, DA, DA, DA, DA stranded wire or solid wire
- Loose wiring inspection don't need to open the transparent end cap

Connection Interfaces

- DALI DT6, Push-DIM
- Strain relief with through wiring function
- Terminal blocks: push-fit terminals

Housing Properties

- Casing: polycarbonate, white
- Type of protection IP20

Typical applications

- For downlight and spot light in both residential, commercial and decorative lighting applications

LED Electronic Looping Control Gear

DALI-2, Push-Dim Constant Current Output

With 14-40VDC 120mA-350mA Adjustable Output Series

PARAMETERS

MODEL	C916-40350DB-F	
Output	Output voltage	14-40V
	Rated current	120-350mA (preselected 120mA)
	Maximum power	14W
	Current tolerance	±5%
	Ripple voltage ²	120mVp-p
	Ripple current	15mA _{p-p}
	Line regulation	±1%
	Load regulation	±3%
	Flicker percentage ³	<1%
	Starting time	≤500mS
	Turn off time	<1S
	Noise ⁴	<20dB
Input	Voltage	Rated:220-240V; Range:200-264V;
	Frequency	Rated:50-60Hz, 0Hz; Range:47-63Hz, 0Hz;
	Power factor	≥0.9; (Output power ≥ 8W)
	I-THD ⁵	≤15% (Output power ≥ 8W)
	Efficiency ⁶	≥86%
	AC current	100mA max.
	Inrush current ⁷	35A
	Inrush current time	6μS
	Leakage current	<1mA
	ON/OFF switches cycle	>100,000
	Standby power	<0.5W
DALI & PUSH Control	Dimming control mode	Amplitude (AM) dimming
	Dimming control type	DALI DT6(1 channels dimming) & and Push Dimming
	DALI Input Voltage	Rated:16V; Range:9.5-22.5V;
	DALI Input (Bus) Current	Rated:1.6mA; Range:1.5-1.8mA;
	Dimming Range	1%-100%
DALI Standard	IEC 62386-101: 2014, IEC 62386-102: 2014, IEC 62386-207: 2009, IEC 62386-209: 2009	
Protection	Over current	Constant current limiting, recovers automatically after fault condition is removed
	Over voltage	Shut down output voltage, with auto-recovery or re-power on to recovery
	Over temperature	Shut down output voltage, recovers automatically after temperature goes down
	Short circuit	Constant current limiting, recovers automatically after fault condition is removed
Safety & EMC	Safety standards	EN61347-2-13; Design refer to TUV EN60950-1, TUV EN61347-1
	Withstand voltage	I/P-O/P:3KV _{ac} I/P-FG:1.5KV _{ac} O/P-FG: 500V _{dc}
	Isolation resistance	I/P-O/P, I/P-FG, O/P-FG:100M Ohms/500V _{dc} /25°C/75%RH
	EMC emission ⁸	EN55015B, EN55022 Class B, EN61000-3-2, EN61000-3-3
	EMC immunity	EN61000-4-2, EN61547, EN55024, EN-61000-4-5 Surge immunity Line-Earth: 1KV, L Line- N Line: 0.5KV;

LED Electronic Looping Control Gear

DALI-2, Push-Dim Constant Current Output

With 14-40VDC 120mA-350mA Adjustable Output Series

Environment	Ambient temperature range ⁹		-25°C ~ +55°C
	Max. case temperature(tc) ¹⁰		80°C
	Relative humidity range		20% ~ 85%RH
	Storage temperature range		-30°C ~ +75°C
max. No. of PSUS(Driver supply unit) on miniature circuit breaker(MCB)	MCB TYPE A	10A	60pcs @ full load
		16A	96pcs @ full load
		20A	120pcs @ full load
	MCB TYPE B	10A	65pcs @ full load
		16A	104pcs @ full load
		20A	130pcs @ full load
	MCB TYPE C	10A	75pcs @ full load
		16A	120pcs @ full load
		20A	150pcs @ full load
	Lifetime(hrs)@tc=65°C		>60,000H
	MTBF [MIL-HDBK-217F(ta=25°C)]		214.8K Hrs min
	Glow wire test		850°C for 5S; 650°C for 30S
	Dimension L x W x H		87.5 x 60 x27.5mm
Warranty years		5 years	
(*If demand other output voltage and output current, contact your sales consultant or contact us: www.kinglumi.com)			

“2” Ripple voltage is measured at 20MHz of bandwidth by using a 12” twisted pair-wire terminated with a 100nF & 47uF parallel capacitor.

“3” The flicker s test data of output current at input @230Vac with maximum output current, detailed reference "AM&PWM dimming technique".

“4” The noise of LED driver is defined as test data when driver tested in noise room with 50~60dB environment, and been hang in 1ft (305mm) inside chamber.

“5” Rated voltage input, rated output current, maximum output current.

“6” The typical efficiency is test data of output current at input @230Vac with 36V output voltage, maximum output current.

“7” The inrush current is test data of 230Vac input, cold start, measured at input current peak.

“8” The driver is considered as a component that will be operated in combination with final equipment. Since EMC performance will be affected by the complete installation, the final equipment manufacturers must re-qualify EMC directive on the complete installation again.

“9” For other than independent use, higher ta of the control gear possible as long as highest allowed tc point temperature is not exceeded.

“10” The tc is defined as the highest permissible temperature which may occur on the outer surface of the power under normal operating conditions and at the rated voltage/current/power or the maximum of the rated voltage/current/power range, refer to “output power vs temperature” section.

LED Electronic Looping Control Gear

DALI-2, Push-Dim Constant Current Output

With 14-40VDC 120mA-350mA Adjustable Output Series

DRIVER PERFORMANCE CURVE

Operating window

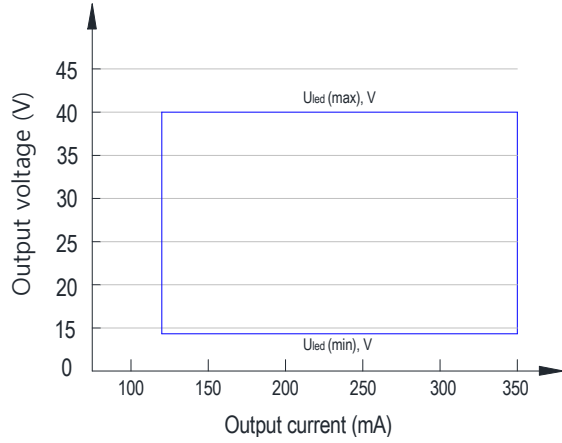

Typical load output

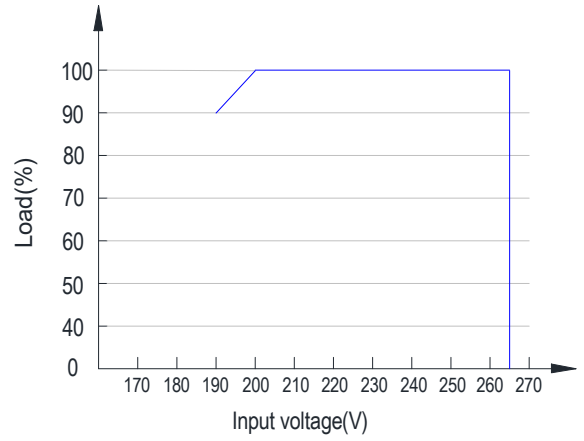

Typical power factor

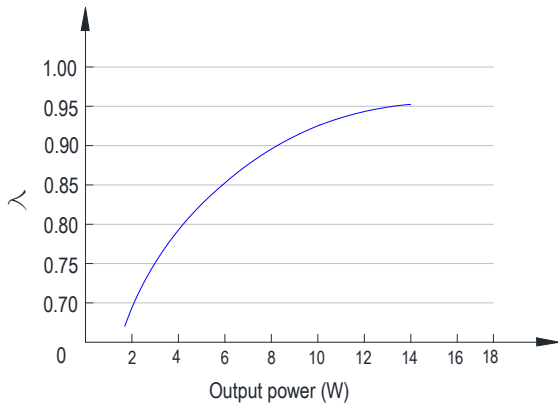

Typical efficiency

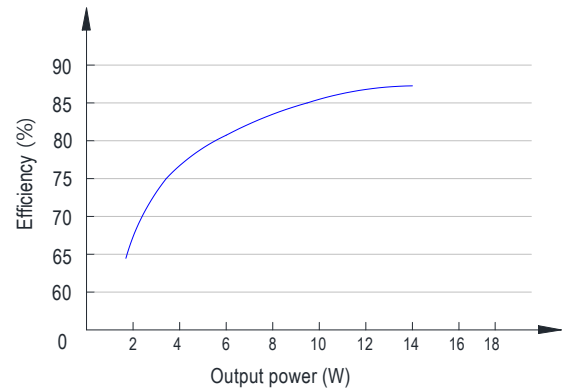

Typical case temperature(tc)

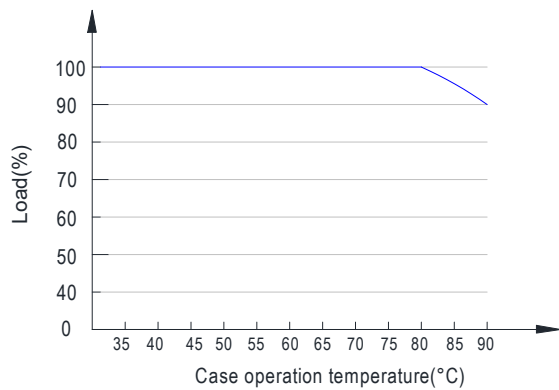

Typical lifetime

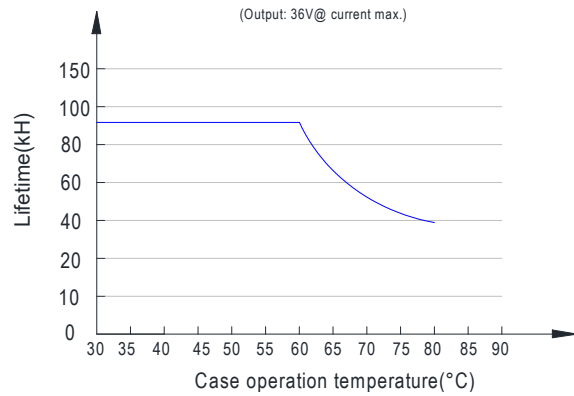

LED Electronic Looping Control Gear

DALI-2, Push-Dim Constant Current Output

With 14-40VDC 120mA-350mA Adjustable Output Series

DIMMING OPERATION

AM&PWM dimming technique

Amplitude Modulation(AM), also known as Constant Current Reduction(CCR) or Analog Dimming. The AM dimming is completely invisible when camera recording but on the other hand a possible LED colour shifting could occur at low level dimming, together with a possible LED light instability due to physical differences between LEDs.

Kinglumi® C9 series driver dimming technique combine the features from AM and Pulse Width Modulation(PWM) dimming. CCR is a very efficient technique for dimming the light output especially on higher range. On lower range, the driver implement high-frequency PWM dimming to ensure high quality dimming for 15-30% down to 1% providing low flicker dimming performance.

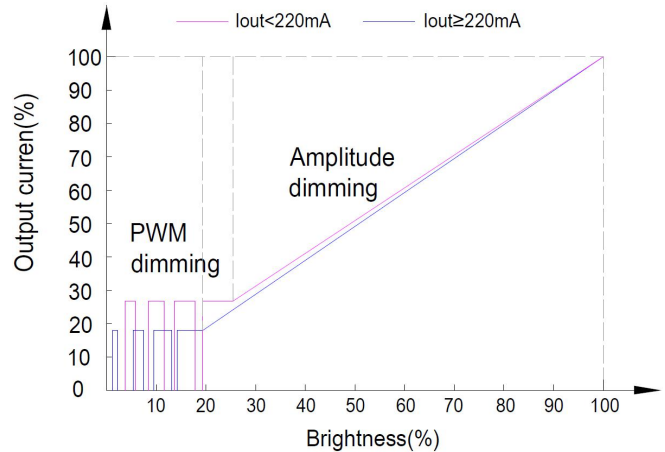

PUSH Dimming

PUSH-DIM, also known as Switch-Dim or Touch-Dim. To be able to make simple light management systems, the C9 driver also integrated PUSH-DIM Function. This makes it possible to dim and switch them directly with mains AC voltage using the PUSH control terminals (PUSH-DIM interface). Only one commercial push-button is required; the controller takes over the drivers. PUSH-DIM may never be used at the same time as a DALI control system.

Circuit diagram

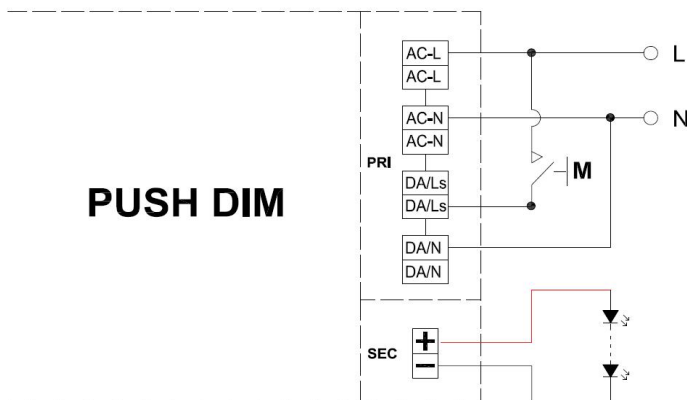

Wiring and cable compensation

- Do not use more than 20pcs C9 driver in a single PUSH-DIM application (up to 20pcs C9 Driver can be controlled by one push-button). The greater the number of C9 series driver controlled imultaneously, the greater the risk of asynchronisms.
- The cable length between the push-button and the farthest C9 series driver may not be longer than 105 meters. Compensation measures must be applied for line lengths required to be more than 105 meters long (bell transformer, resistance).
- The push button can only be connected to the AC/L and PUSH terminals of the driver. It results in the short circuit if the Push Button is connected to the AC/N terminal.

LED Electronic Looping Control Gear

DALI-2, Push-Dim Constant Current Output

With 14-40VDC 120mA-350mA Adjustable Output Series

Instructions

Operation	Action duration	Action
Ultra Short Press	<0.04 sec	Won't cause any action
Briefly Press	0.04-0.5 sec	Light ON/OFF
Press and hold at ON status	0.50-5.0sec	Brightness Dimming down to 1%, or up to 100%
Press and hold at OFF status	0.50-5.0sec	Brightness Dimming From 1% up to 100%
Long Press	>10.0 sec	Reset to factory settings(up to 50%)

Note:

- a) Factory defaults 100% brightness, dimming level down to 1%.
- b) Built-in with permanent memory:
Light returns to the previous dimming level when switched off and on again, even at power failure.
- c) Synchronization of switching state and dimming direction:
For physical reasons, a PUSH-DIM system can work asynchronously; in other words, the switching state and dimming direction of the individual luminaires are different. The following steps are used to synchronize a PUSH-DIM system:
 1. Step: Press and hold (> 0,5 s) → All luminaires switch on
 2. Step: Press briefly (< 0,5 s) → All luminaires switch off
 3. Step: Press and hold (> 0,5 s) → All luminaires switch on and dim
- d) The PUSH-DIM wiring and the operator button must be rated for mains voltage (240V).
- e) Warning: Make sure the conduct core connected to PUSH terminal is not exposed, as it connected to the live wire.

Asynchronism

As a matter of principle, asynchronisms can occur with push-button operation in systems with more than one C9 driver. The higher the number of C9 Driver and the longer the control line length, the greater the chance of asynchronisms. In order to avoid lighting installations running asynchronously in practice, the permissible number of C9 series and the total line length of 25 meters must be adhered to.

DALI 2 Dimming

The DALI logo, is only allowed to use for members of the DiiA. The LEDGEAR® C9 series is DALI-compliant to any DALI master or application controller if they bear the DALI logo.

Instructions

- a) Compatible with both DALI-2 application controller or DALI-I master, please make sure they also qualified and listed in the DiiA website.
- b) Connect the DALI signal to the DA1 and DA2 terminals (polarity-free)
- c) Addressing possible:
 - Individually (max. 64 IP addresses)
 - In groups (max. 16)
 - All together
- d) The least dimming depth of DALI is of 1% * Iout.
- e) Built-in with permanent memory: light returns to the previous dimming level when switched off and on again, even at power failure.
- f) Supports star, tree, serial, parallel wiring ,but not supports ring wiring

LED Electronic Looping Control Gear

DALI-2, Push-Dim Constant Current Output

With 14-40VDC 120mA-350mA Adjustable Output Series

- g) If the C9 series are not reacting to the command of the control unit. Please inspect the wiring; approx. 16 V DC must be applied to the DALI terminal of the C9 series.

DALI INPUT	MIN	TYP	MAX
High level	9.5V	16V	22.5V
Low level	-6.5V	0	6.5V

- h) DALI bus communication length and input wire diameter

Wire Diameter	DALI Bus Communication length
0.5 ² mm	100m Max.
0.75 ² mm	150m Max.
1.0 ² mm	200m Max.
≥1.5 ² mm	300m Max.

DIAGRAM&INSTALLATION MANUAL

Isolated circuit (Fly-back CV + DC-DC control)

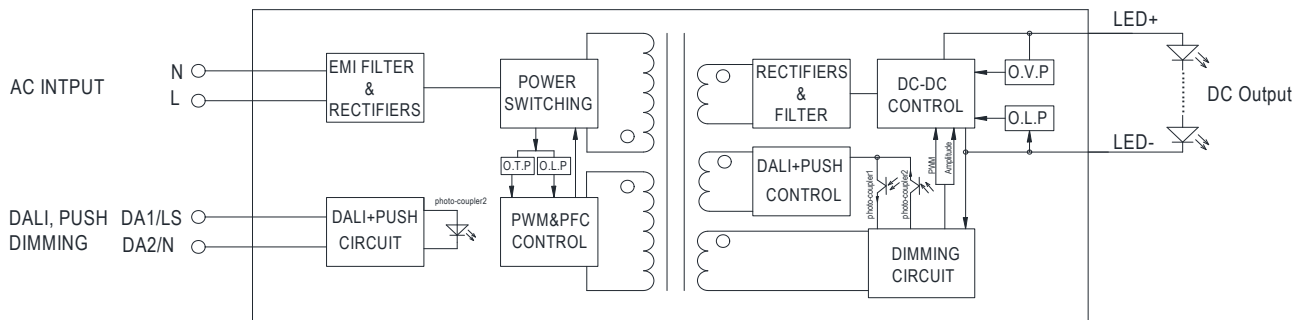

Insulation between circuits

Electric Insulation	Input	Output	Housing	DALI	PUSH
Input	X	Reinforced	Reinforced	Basic	Non
Output	Reinforced	X	Basic	Reinforced	Reinforced
Housing	Reinforced	Basic	X	Reinforced	Reinforced
DALI	Basic	Reinforced	Reinforced	X	Basic
PUSH	Non	Reinforced	Reinforced	Basic	X

LED Electronic Looping Control Gear

DALI-2, Push-Dim Constant Current Output

With 14-40VDC 120mA-350mA Adjustable Output Series

Release of the wiring

Press down the "push button" and remove the cable from front.

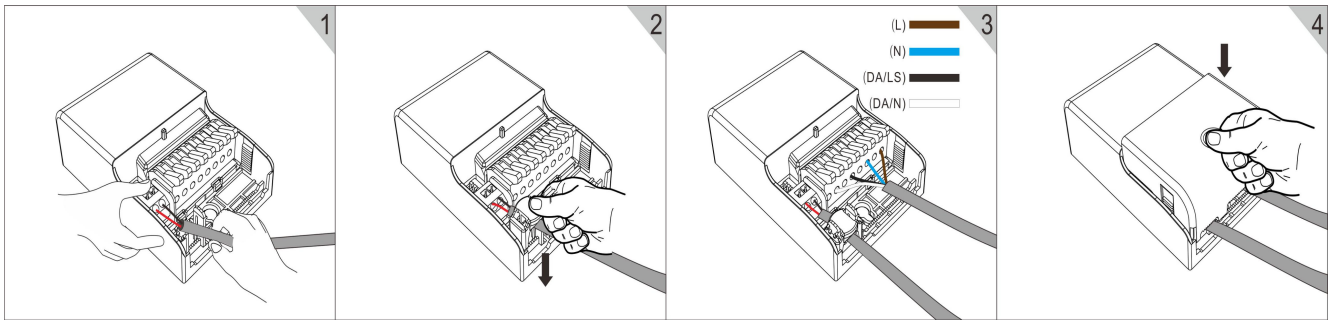

Looping Circuit diagram

These LEDGEAR® drivers provides "through wiring functions" at primary for the L,N input and DALI1,DALI2, which allows quick looping from driver to driver and save the installation labour.

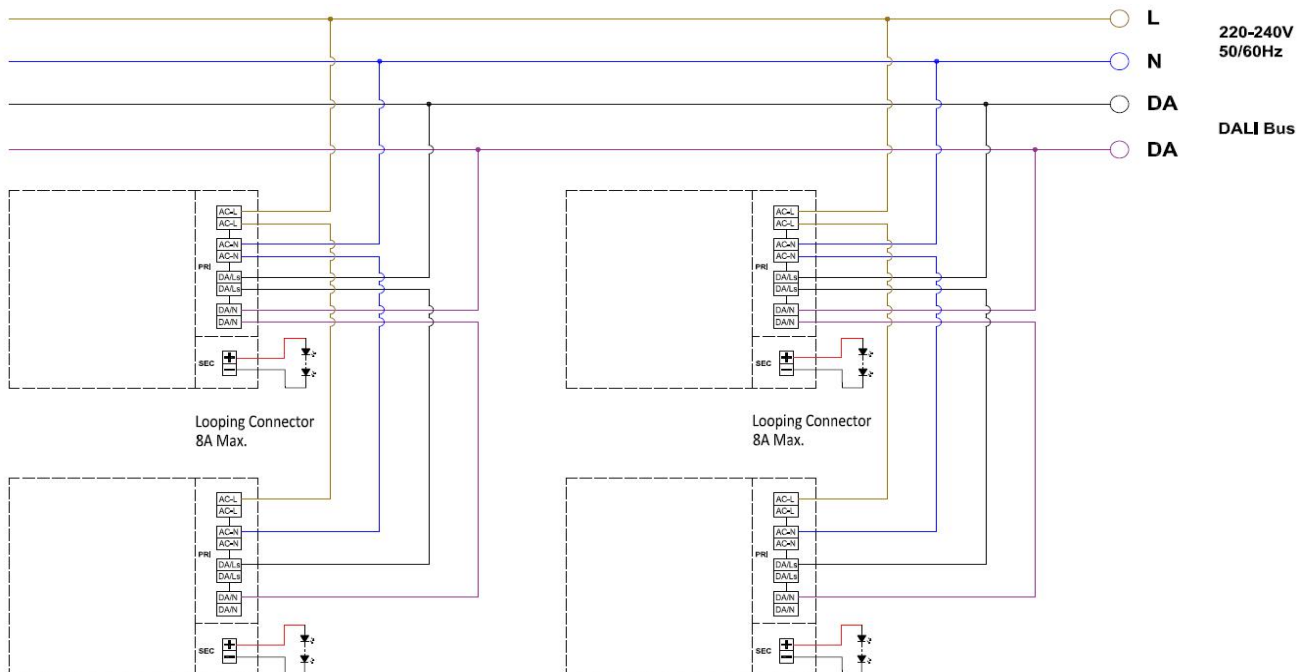
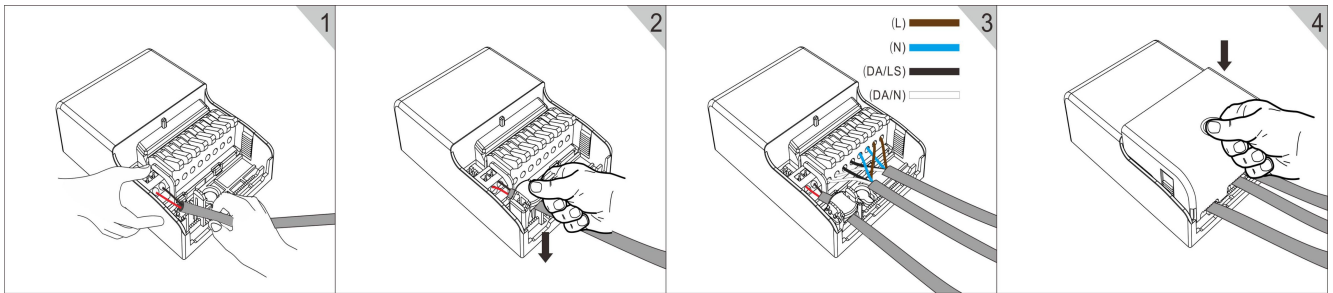

LED Electronic Looping Control Gear

DALI-2, Push-Dim Constant Current Output
 With 14-40VDC 120mA-350mA Adjustable Output Series

Wiring type and cross section

The wiring can be in stranded wires with ferrules or solid with a cross section of 0.75–2.5 mm². Strip 9-12mm of insulation from the cables to ensure perfect operation of the push-wire terminals. Use one wire for each terminal connector only

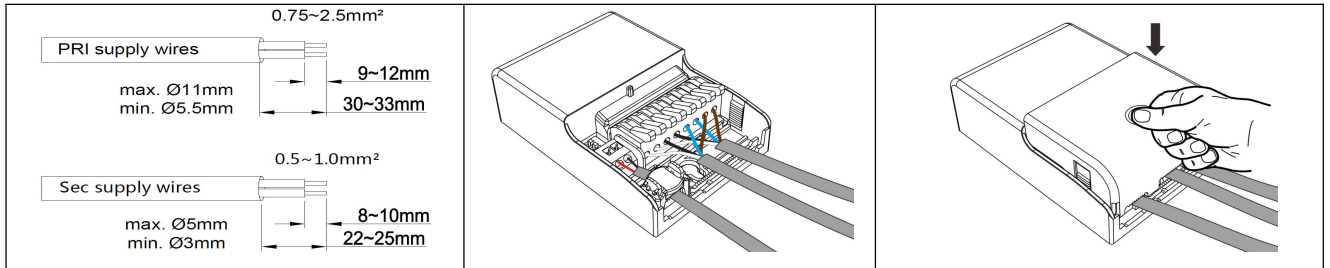

Wiring guidelines

- All connections must be kept as short as possible to ensure good EMI behavior.
- Mains leads should be kept apart from LED Driver and other leads (ideally 10 – 30 cm distance).
- Incorrect wiring can damage LED modules.
- The wiring must be protected against short circuits to earth (sharp edged metal parts, metal cable clips, louver, etc).

Miniature circuit breaker application

Total continuous current of the drivers and installation environment must always be considered and taken into calculations when installing drivers behind miniature circuit breaker(MCB).

Quantity of drivers(350mA Output) per miniature circuit breaker 16 A Type C

Based on inrush current I_{peak}	Typ. peak inrush current I_{peak}	1/2 value time, Δt	Calculated energy, $I_{peak}^2 \Delta t$
120pcs	35A	11uS	0.014A ² s
			<p>Example calculation of total drivers amount limited by continuous current: $n(I_{cont}) = (16 A (I_{nom}, t_a) / \text{"nominal mains current with full load"}) \times 0.75$. This calculation is an example according to recommended precautions due to multiple adjacent circuit breakers (> 9 MCBs) and installation environment ($t_a=30^\circ C$); variables may vary according to the use case. Both inrush current and continuous current calculations are based on "Schneider Acti9" series circuit breakers. More specific information in "Schneider Acti9" series circuit breaker documentation.</p>

NOTE ! Type B or C MCB's are strongly recommended to use with the LED driver.

LED Electronic Looping Control Gear

DALI-2, Push-Dim Constant Current Output

With 14-40VDC 120mA-350mA Adjustable Output Series

Fixing conditions

Dry, acid-free, oil-free, fat-free. It is not allowed to exceed the maximum ambient temperature (ta) stated on the device. Minimum distances stated below are recommendations and depend on the actual luminaire. Is not suitable for fixing in corner.

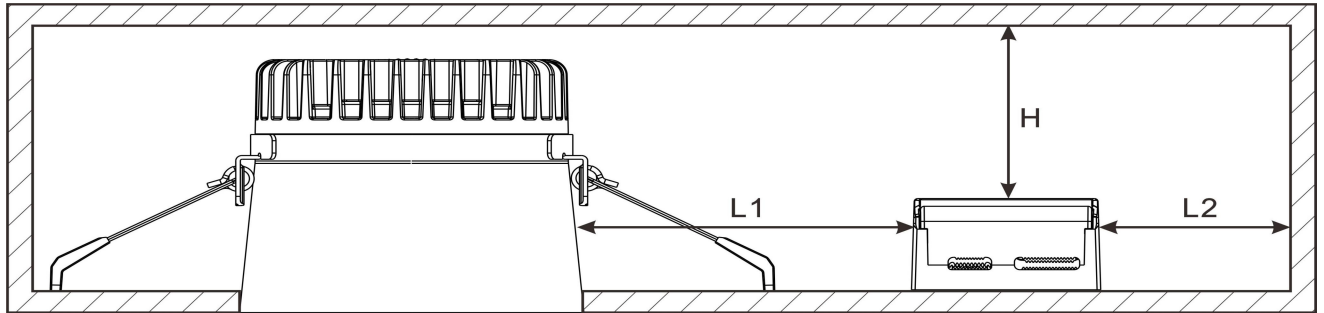

Model	Size	L1(min.)	L2(min.)	H(min.)
C916-40350DB-F		70mm	20mm	20mm

DIP Switch Table

LEDGEAR® C9 series is a multiple-stage constant current driver, selection of output current LED current through DIP switch is exhibited below

Output			DIP Switch		
Voltage	Current	Power	1	2	3
14-40V	120mA	4.8W	ON	ON	ON
	160mA	6.4W	ON	-	ON
	180mA	7.2W	-	ON	ON
	220mA	8.8W	ON	-	-
	250mA	10W	-	ON	-
	280mA	11.2W	-	-	ON
	350mA	14W	-	-	-

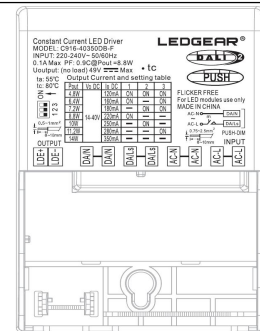

MECHANICAL

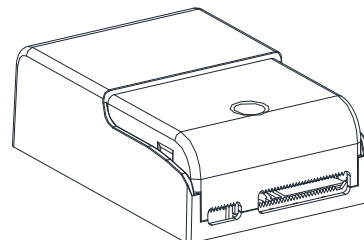
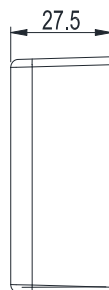
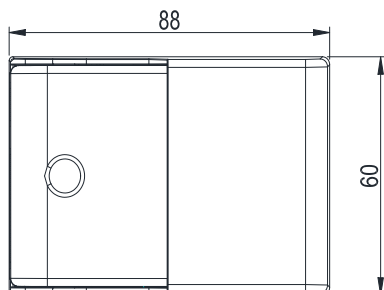

Unit:mm

PACKAGING

Part Number	Dimension	Gross Weight	Net Weight	Qty/Carton
C916-40350DB-F	355x315x215mm	5.5kg	4.3kg	40pcs

LED Electronic Looping Control Gear

DALI-2, Push-Dim Constant Current Output

With 14-40VDC 120mA-350mA Adjustable Output Series

VERSION #

#	MODIFICATIONS	Date.
1	Version 1.0	2020.11.11
2		
3		
4		
5		
6		
7		
8		
9		
10		
11		
12		